

wrap  
brand  
identity  
guideline

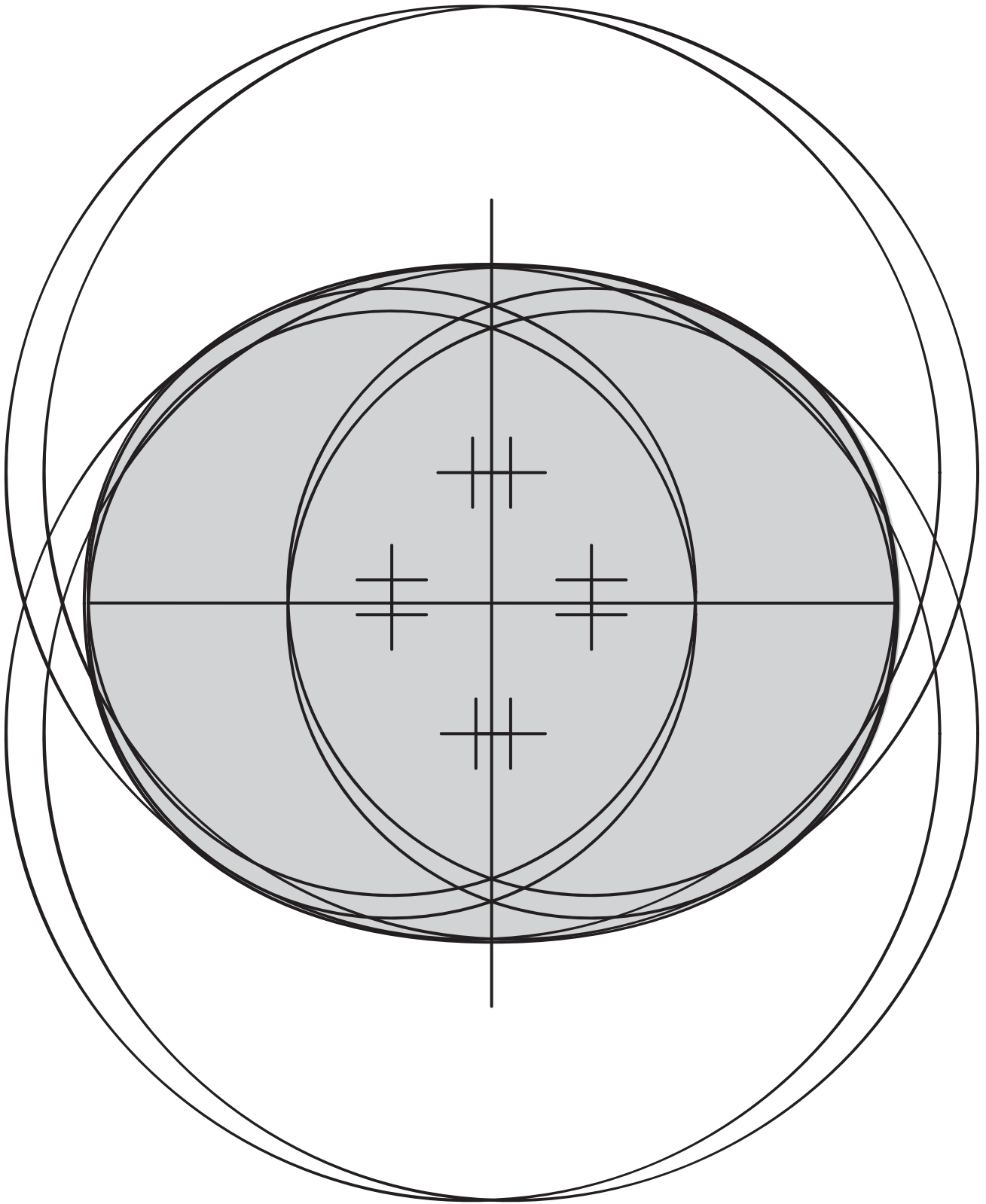

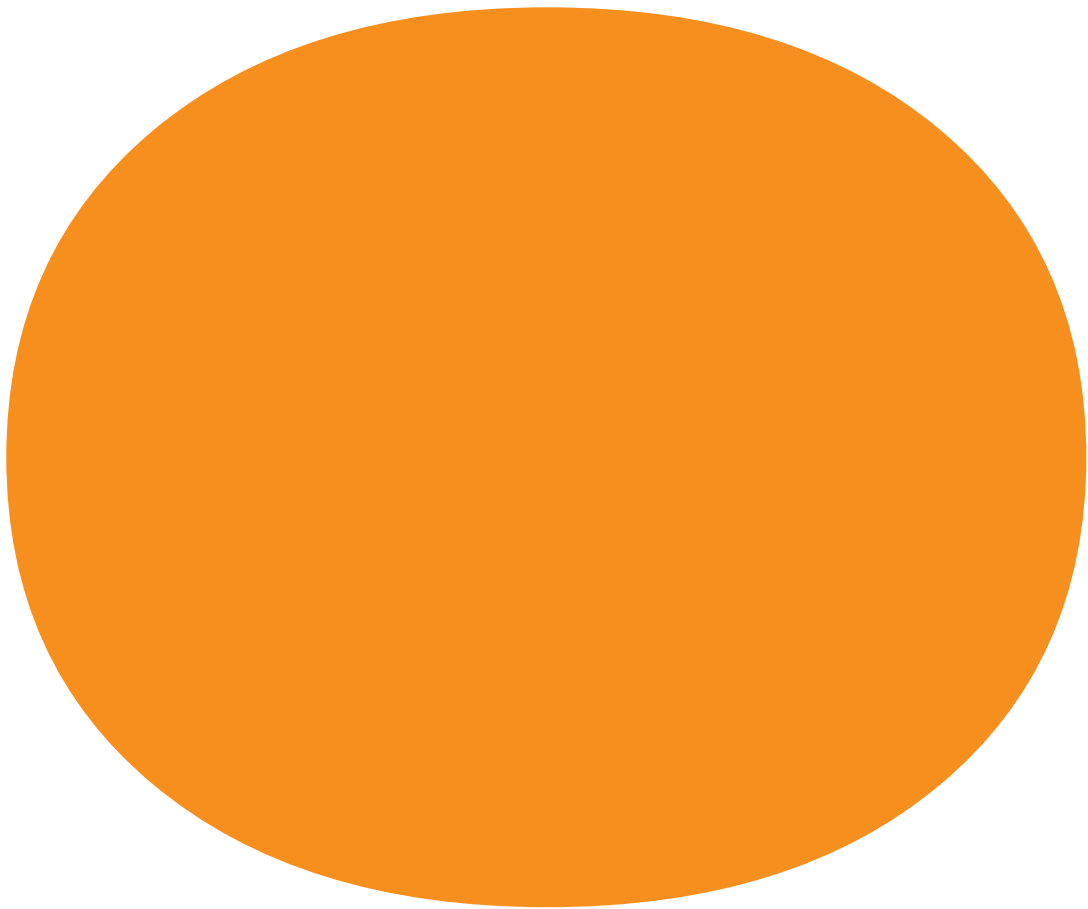



wrap

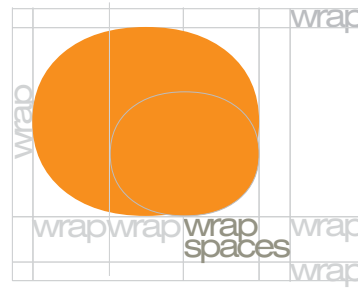
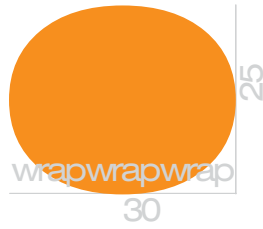

Proportions

Exclusion Zone & text positioning

## Preferred format

The WRAP logo is available in three formats, a preferred format and two secondary formats. The preferred format (M) should be used in most applications.

The relationship between the masterbrand name and the symbol is fixed. Never distort or attempt to alter this relationship.

Use format (B) for book covers and ads.

When reproducing the WRAP logo in small sizes it is necessary to use the minimum size symbol (S) when the word WRAP width is below 7mm .

A minimum clear space zone should be maintained around the logo as shown.

Always reproduce the masterbrand logo using master artwork available from Wrap spaces B.V.

(email: [info@wrapspaces.com](mailto:info@wrapspaces.com)).

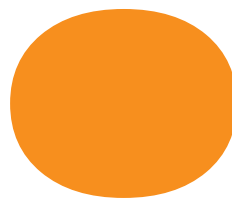
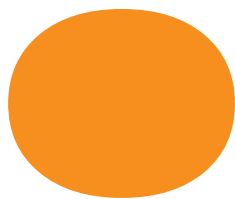
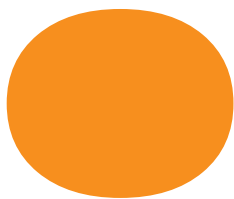

B

wrap

wrap spaces

7 mm

7 mm

Do not use it below 7mm in width.

Do not use it below 7mm in width.



M

wrap

wrap spaces

7 mm

7 mm

Do not use it below 7mm in width.

Do not use it below 7mm in width.



wrap

wrap spaces

7 mm

7 mm

Use it below 7mm in width.

Use it below 7mm in width.

S

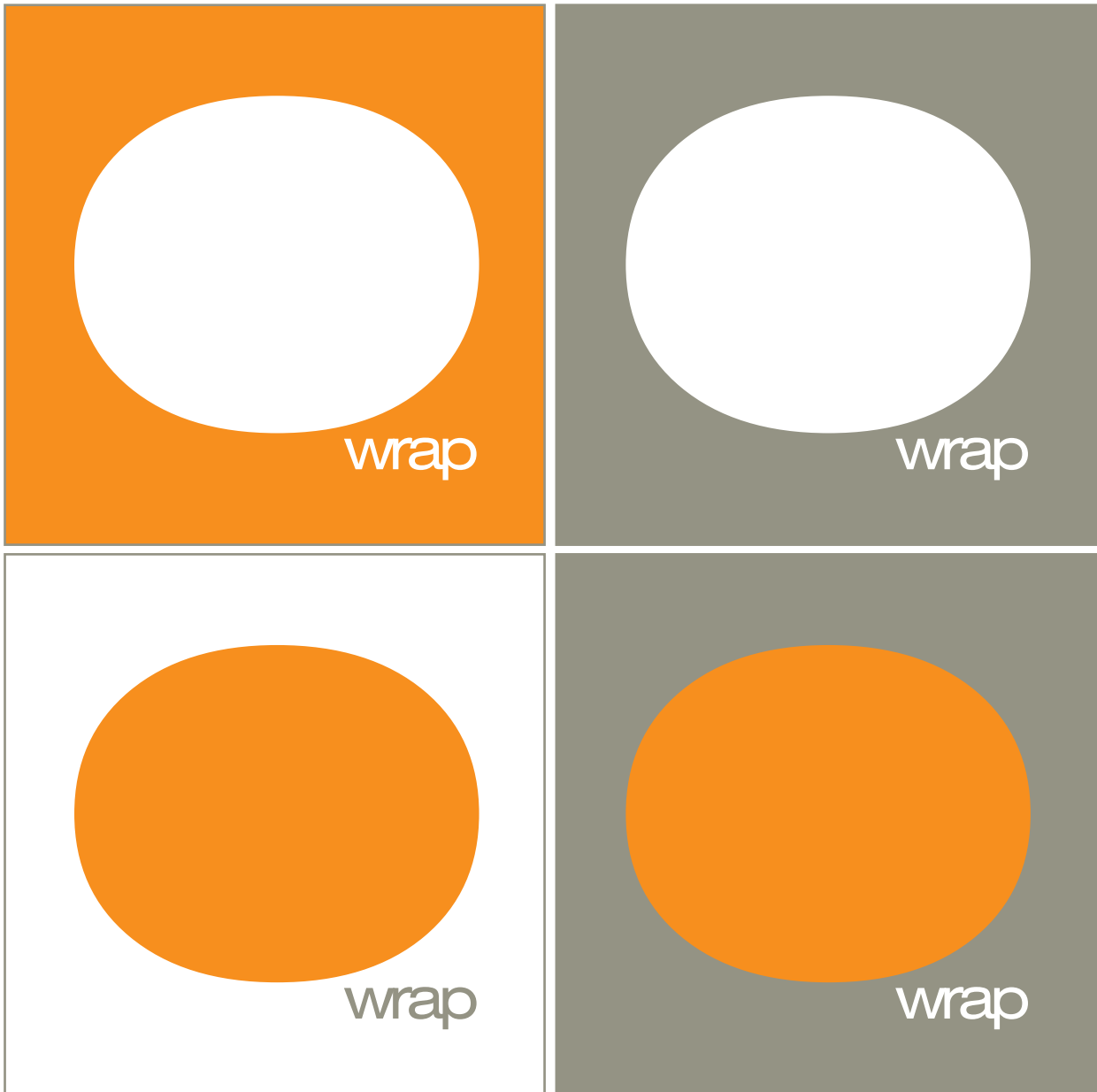

Primary Typeface: Swiss721 Ex BT

Two primary colours:

**PANTONE ORANGE 021 U**

PANTONE 416 U



**Sylvia M. de Zeeuw**

project manager  
+31 (0) 6 2738 2063  
sylvia.dezeeuw@wrapspaces.com

We are Wrap Spaces. You can visit us at **Achterstraat 5, 4115RP Asch, The Netherlands**. Or call us at: **+31 (0) 345 504 629** for directions and more about us visit **[www.wrapspaces.com](http://www.wrapspaces.com)**

Achterstraat 5, 4115RP Asch,  
The Netherlands.  
+31 (0) 345 504 629

[www.wrapspaces.com](http://www.wrapspaces.com)  
[info@wrapspaces.com](mailto:info@wrapspaces.com)



wrap  
spaces

1

L

[www.wrapspaces.com](http://www.wrapspaces.com)  
[info@wrapspaces.com](mailto:info@wrapspaces.com)



wrap  
spaces



wrap  
spaces

Achterstraat 5, 4115RP Asch, The Netherlands.



venster

